

ICE 823 B Vibratory Hammer

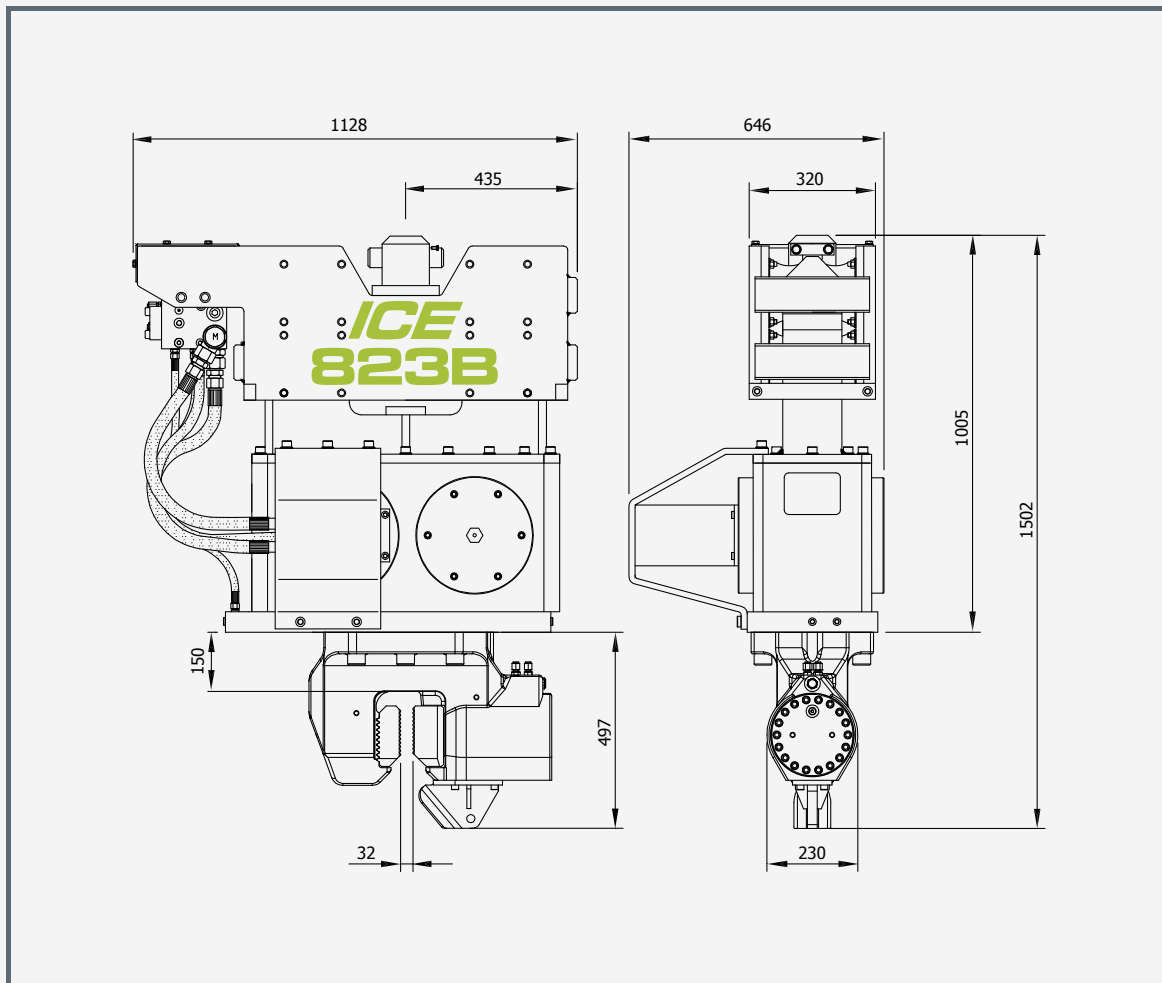

Specifications	823B		Clamps:	
Eccentric moment	8	kgm		
Max. centrifugal force	464	kN	Sheet pile clamp	60TU
Max. frequency	2300	rpm	Transport weight per piece	250 kg
Max. amplitude excluding 60TU	23.2	mm		
Max. amplitude including 60TU	17	mm		
Max. static line-pull	120	kN		
Max. operating pressure	350	bar		
Max. oil flow	185	l/min		
Forced lubrication	no			
Dynamic weight excluding 60TU	690	kg		
Dynamic weight including 60TU	940	kg		
Total weight excluding 60TU & hoses	1060	kg		