

► ABI Mobilram

■ TM 14/17 SL

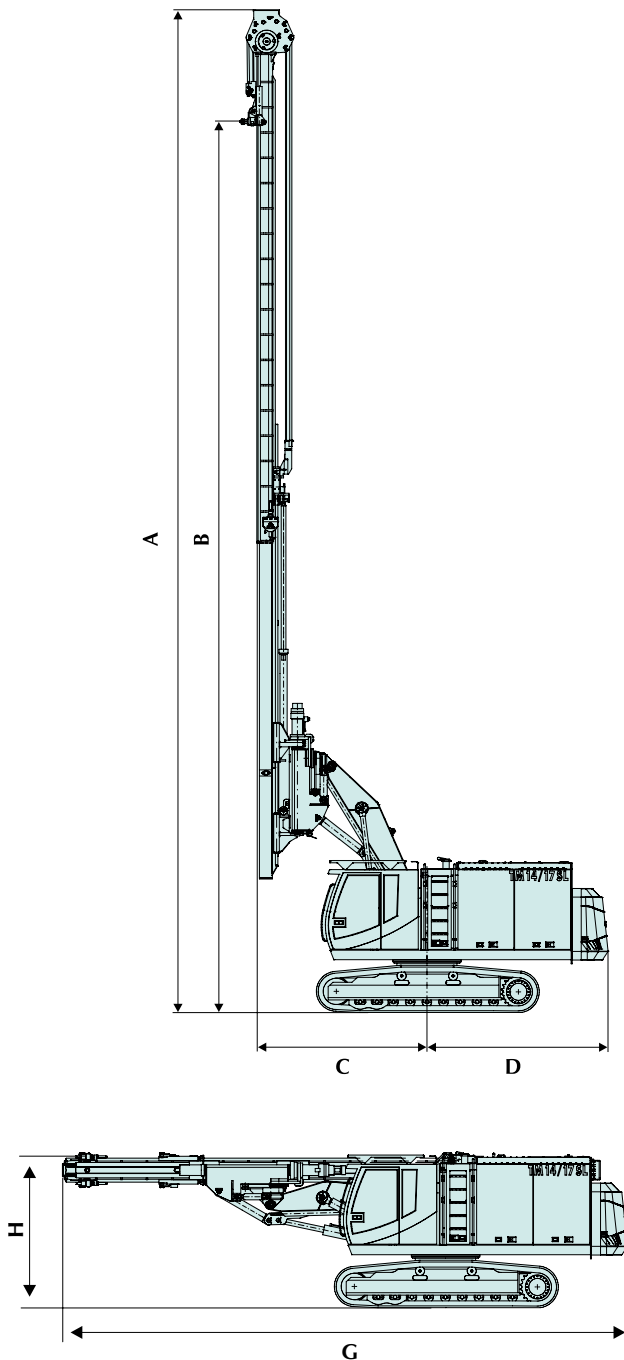

Technical data	Unit	TM 14/17 SL
Leader inclination front/rear	degree max.	4/5
Leader inclination laterally	degree max.	4
Leader slewing range	degree max.	+/- 100
Prestressing force leader cylinder	kN max.	90
Extraction force leader cylinder	kN max.	175
Load capacity	kg max.	7000
Torque absorption	daNm	4200
Auxiliary winch lifting capacity	kN max.	auf Anfrage
Auxiliary winch rope speed	m/min	-
Weight - depending on carrier unit**	t approx.	45 - 50
VIBRATOR		MRZV 20 VV
Dimension		
A Height min./max.	mm	11230 - 21030
B Max. height up to rapid changing device	mm	18900
C Center to guide	mm	3350 - 5180
D Center to back underground lowering depth	mm	3490 - 3810 3190
E Leader mast guide width	mm	500
F Leader mast width	mm	50
G Length / transport	mm	11700
H Height / transport	mm	3400
Width / transport	mm	3000

BASE CARRIER	Unit	SR 35 T-E
ENGINE		
ENGINE		CAT C18
Engine power EU Stage Tier 4 final	kW	470
Hydraulic flow rate	cm ³	2 x 210 1 x 95, 1 x 60
Nominal oil pressure	MPa	33
Fuel tank capacity	l	810
Standard undercarriage		
Pulling force	kN	350
Track gauge	mm	2400
Outriggers - / Track shoes width	mm	600*
Optional - Hydraulic extendable undercarriage		
Pulling force	kN	340
Track gauge	mm	2200 - 3300
Track shoes width	mm	700*

*Optional track shoes width 700, 800, 900 mm